

# RB190

Storage Bin 243 kg



Complete range: **RB100 - RB150 - RB300**

## Technical features

- Convenient & hygienic internal ice scoop holder.
- Exterior panels in durable stainless steel.
- Polyurethane Insulation.
- High density, non-corroding Polyethylene bin liner, is designed with easy-to-clean rounded corners, and resists scratches and scuffs from ice scoops.
- Robust door frame will resist operational abuse.
- Rounded door-lip profile allows an easy reach for enhanced ease of operation.
- Fully removable door gasket seals door opening to reduce ice melt, easily disassembled for manual cleaning.
- Internal ice deflector enhances ice distribution to maximize bin storage capacity.
- Load resistant, stainless steel adjustable legs.
- Bin Caster available on request for selected models.
- Storage bin base drain tube conveniently rotates at 360° radius to allow ease-of-connection with any floor water drain position.



## Bin capacity

243 kg of ice

## Dimensions and weight

Net size WxDxH	768 x 866 x 1274 mm
Net weight	55 kg
Shipping size WxDxH	830 x 950 x 1310 mm
Shipping weight	70 kg

## Technology and Certifications



Specifications and design are subject to change without notice

# RB190

Storage Bin 243 kg



Complete range: **RB100 - RB150 - RB300**

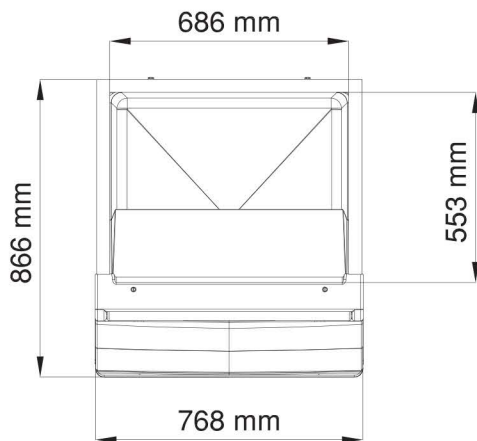
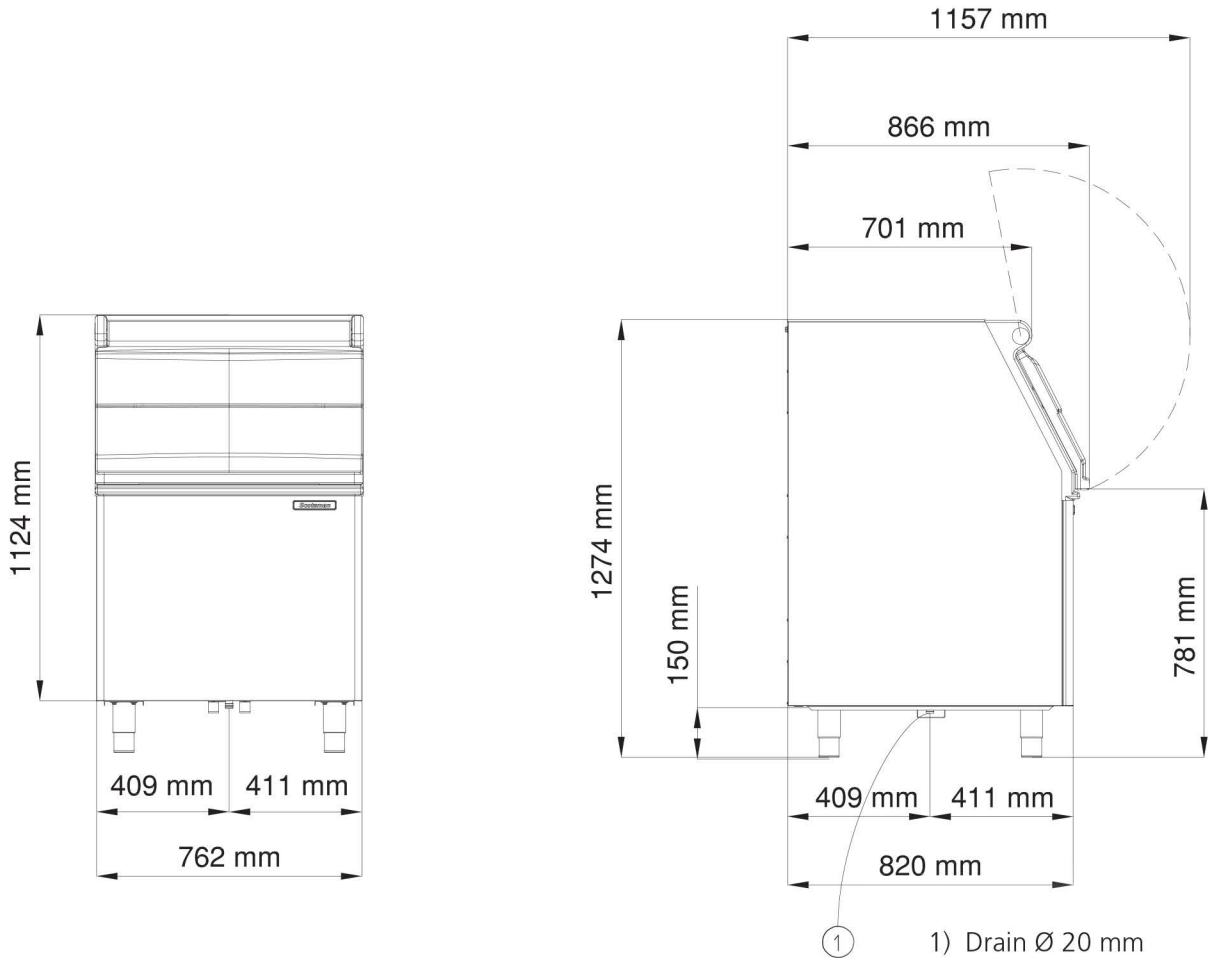

Factory 12 Sandown Square  
56 Smith Rd Springvale Vic 3171

[www.frostline.com.au](http://www.frostline.com.au)  
(03) 9562 4400

